

TOWMASTER

A-frame by Roadmaster

1,700 kilogram capacity A-frame
model number 505-EUJ

Owner's Manual

Entire contents of manual must be read by owner



Time Tested • Time Proven

ROADMASTER, Inc. • 6110 NE 127th Ave. • Vancouver, WA 98682

800-669-9690 • Fax 360-735-9300 • roadmasterinc.com

© 2015-16 ROADMASTER, Inc. All rights reserved. 855389-01 08.16

Welcome to the ROADMASTER family!

This manual has been prepared to acquaint you with the installation, operation, care and maintenance of your A-frame, and to provide you with important safety information.

Read your owner's manual cover to cover. Understand how to install and operate your A-frame, and carefully follow the instructions and safety precautions.

We thank you for your patronage and greatly appreciate your discerning taste.

Contents

Safe towing practices	1
Connecting and disconnecting	
Connecting the A-frame	2-3
Disconnecting the A-frame	3-4
Care and cleaning	4
Coupler information	5
Limited warranty	6
Optional equipment and accessories.....	7

Save this manual

Save this manual for future reference. It contains important sections relative to safety, use, maintenance and other information. Therefore, make sure this manual is always with you when you're towing.

You may download or print a copy of the most current manual at www.roadmasterinc.com (under 'Support').

Your A-frame serial number...

...is located on the interior of one of the A-frame arms.

Write down the serial number in the space below and retain for future reference.

Serial number: _____

All illustrations and specifications contained herein are based on the latest information available at the time of publication. ROADMASTER, Inc. reserves the right to make changes, at any time, without notice, in material, specifications and models, or to discontinue models.

WARNING

Read all instructions before installing the A-frame, or before towing a vehicle. Failure to understand how to properly install or operate the A-frame could result in property damage, personal injury or even death.



Safe towing practices

To ensure your safety and that of your passengers, as well as the safety of others on the road, follow these safe towing practices at all times.

CAUTION

ROADMASTER recommends reversing with the towed vehicle attached be kept to a minimum, and only as a necessity.

Backing up with the towed vehicle attached may cause the towed vehicle to “jackknife,” which could cause non-warranty damage the A-frame.

- **Be sure the vehicle can be towed** before taking it on the road. Failure to properly equip the vehicle will cause severe damage to the transmission or the transaxle, unless the vehicle’s manufacturer has approved the vehicle for flat towing. If this is the case, check the vehicle’s owner’s manual for the proper procedure(s) to prepare the vehicle for towing.

- **The A-frame must be approximately level with the ball hook on the motorhome** – no more than four inches above or below level.

Towing with the A-frame at a severe upward or downward slope may force the coupler off the ball hook on sharp inclines or declines.

- **The steering wheel must be unlocked and free to turn when towing.** Failure to do so can cause severe tire and equipment damage.

- The TowMaster A-frame is rated at a maximum of 1,700 kilograms carrying capacity; therefore **the weight of the towed vehicle and all its contents cannot exceed 1,700 kilograms.**

- **The A-frame must be properly secured with pins before towing.** Unless the A-frame is secured to both vehicles with all appropriate pins, the towed vehicle will detach.

- **Inspect the system before towing** – if any component is damaged, replace it before towing. Also, check the coupler ball clamp and ball socket (Figure 1) for fractures or cracks in the steel.

- **This A-frame is designed for use on paved roads only.** ROADMASTER does

not recommend off-road towing, nor does ROADMASTER warrant the A-frame for off-road use.

- **Never tow a vehicle with one of a comparable weight.** The towed vehicle’s weight should never exceed 40 percent of the towing vehicle’s weight.

Towing a vehicle with one of similar weight will cause the towed vehicle to override the towing vehicle, resulting in “jackknifing.” Serious damage to both vehicles, as well as the towing system could result.

- **Always stand to one side and as close to the motorhome as possible when releasing the A-frame locking**

mechanisms. Never stand between the adjustable arms, or put any part of your body between the adjustable arms, when releasing the A-frame – the towed vehicle may lurch forward when the locking mechanisms are released.

- **Check the motorhome turning radius.** Some motorhome chassis have such a tight turning radius that the motorhome can hit the towed vehicle. Before getting on the road with your towed vehicle, you should test your turning radius in an empty parking lot.

- **Keep the A-frame clean and well-lubricated.** As is the case with most precision equipment, frequent cleaning and care results in better performance and longevity.

Refer to the section titled “Care and cleaning” for further information.

WARNING

Failure to follow these instructions may cause property damage, personal injury or even death.

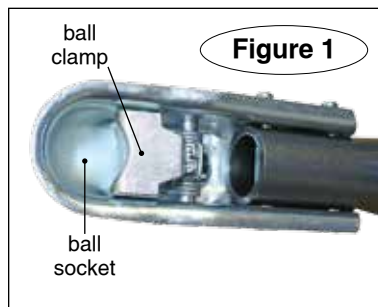

Connecting the A-frame

Center and adjust the A-frame

Note: it is only necessary to center and adjust the A-frame once for any particular vehicle.

1. Insert both of the towing arms (Figure 2) through the holes in the towed vehicle's fascia and into the threaded holes in the bumper core. Tighten them as much as possible without using a wrench.

Then, as shown in Figure 2, unthread each towing arm just enough so that the holes at the end are parallel with the ground.

2. Holding both of the A-frame arms together, attach either arm to its corresponding towing arm with the included linch pin (Figure 3).

3. Extend the other arm across the towed vehicle and attach it to the other towing arm.

4. Pull the coupler (and the two A-frame arms with it) away from the towed vehicle, as far as they will go. The coupler must be approximately centered between the towing arms on the bumper core.

Both Autowloks (Figure 3) will engage – the buttons will pop up.

5. Using a torque wrench, tighten the two bolts at the yoke (Figure 3) to 71 ft./lbs. (96 N-M).

6. The A-frame is now centered and adjusted to your towed vehicle.

If you wish to tow a different vehicle with the A-frame, untighten the two yoke bolts and repeat the steps above.

To connect the A-frame for towing, follow the steps below.

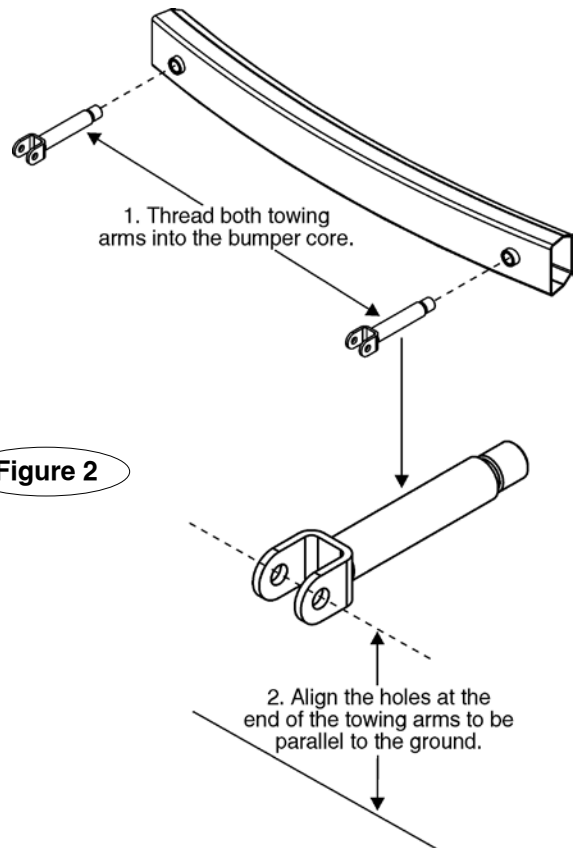

Figure 2

Connecting the A-frame for towing

1. Drive the towed vehicle within three or three-and-a-half feet of the motorhome.

Put the vehicle in gear (park), set the emergency brake and chock one of the wheels.

2. Connect both A-frame arms to the towing arms with the included linch pins.

3. Lift the coupler up and move it forward or backward, as needed, to maneuver it over the ball hook.

If one of the A-frame arms does not slide forward or backward, press down on the Autowlok button to unlock it.

4. Press and hold the coupler locking trigger (Figure 4) and lift the handle (Figure 4) up.

Lower the coupler over the ball hook so that it completely covers it; release the handle.

5. Be certain the coupler is properly locked onto the ball hook – the handle must be completely lowered, as shown in Figure 4, with the coupler completely covering the ball hook, for the coupler to be locked onto the ball hook.

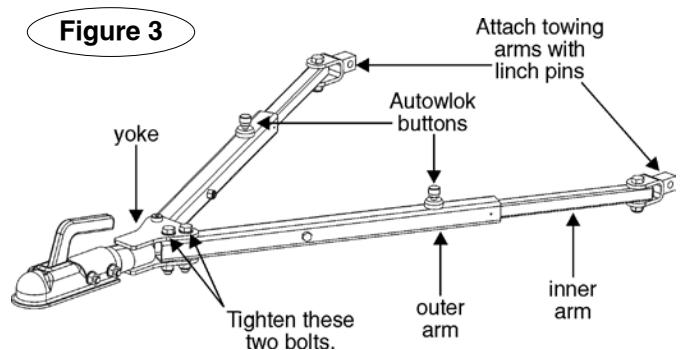

Figure 3

! WARNING

If the coupler is not properly locked onto the ball hook, as described above, it will release during towing. The A-frame will separate from the motorhome, which may cause property damage, personal injury or even death.

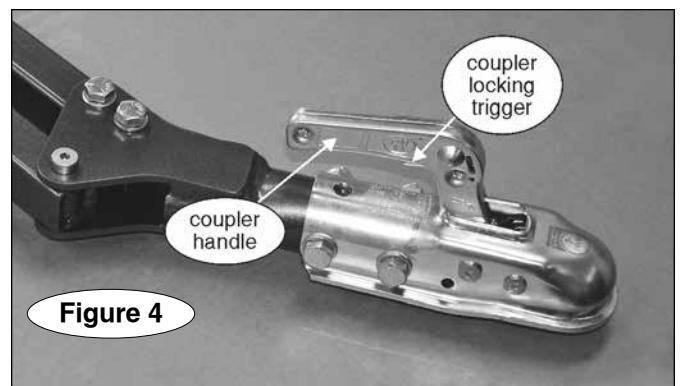

Figure 4

continued on next page

Connecting the A-frame

continued from preceding page

6. Plug in the lighting power cord, according to the supplier's instructions and verify that all lighting systems are functioning.

Before towing the vehicle, make certain that the steering is unlocked, the transmission is in the proper setting, and the emergency brake is released. Remove the wheel chock.

Check the owner's manual for the proper towing procedures or requirement(s) for the vehicle to be towed.

WARNING

Do not tow the vehicle until the A-frame is properly attached with all pins, or the vehicle will detach, which may cause property damage, personal injury or even death.

When you drive away, steer briefly to the left and then to the right, to extend, self-center and lock the A-frame.

Always stop at this time. Check the A-frame to ensure that both arms are locked, before assuming highway speed. Additionally, check the other components of your towing system, to ensure that they are fully engaged.

WARNING

Both A-frame arms must be locked before towing. If they are not, the momentum of the towed vehicle will apply excessive force to the A-frame arms and other components of the towing system, which may cause the towing system to fail, resulting in property damage, personal injury or even death.

Disconnecting the A-frame

1. Disconnecting the A-frame is essentially the reverse of connecting it.

Before you begin, always try to park on level ground, with the towed vehicle in line with the motorhome. This will eliminate most of the tension between the two vehicles, allowing for an easier disconnect.

2. Chock one of the wheels, to prevent a runaway vehicle.
3. Push down on the Autowlok buttons to release the locking mechanisms.

WARNING

When the locking mechanisms are released, the towed vehicle may surge forward. For this reason, always stand to one side when disconnecting the A-frame. Never stand between the adjustable arms, or put any part of your body between the adjustable arms.

CAUTION

Never use a hammer or mallet to disconnect the Autowlok buttons. The A-frame arms will not automatically lock if the Autowlok buttons are damaged.

4. Pull back on the coupler locking trigger and lift the handle (Figure 4) to release the coupler. Lift the coupler

WARNING

Do not tow a vehicle with a ball hook or any supplementary equipment rated less than the actual weight of the towed vehicle and all its contents.

If any supplementary towing equipment is not rated at the weight of the towed vehicle and all its contents it may fail during towing, causing property damage, personal injury or even death.

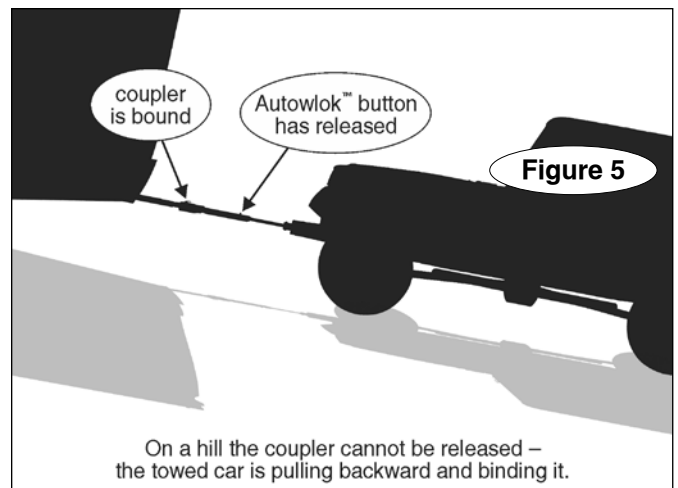

off the ball hook.

Note: if you must park on an uphill incline, you may find that you cannot release the coupler even with the Autowlok buttons released. The weight of the towed vehicle trying to roll back (Figure 5) is binding the coupler in place.

Allow the towed vehicle to idle forward just enough to
continued on next page

Disconnecting the A-frame

continued from previous page

take the tension of this weight off the coupler. Then hold the vehicle in position by first applying the emergency brake, then shifting into park.

Once the tension is off, pull back on the coupler locking lever to release the coupler.

5. Pull the lynch pins from both of the A-frame arms to disconnect them; collapse the arms.

6. Store the A-frame in any covered location that will protect it from the elements.

Care and cleaning

As is the case with most precision equipment, frequent cleaning and care results in better performance and longevity. Use the following guidelines to keep your A-frame clean and well-lubricated.

Always clean the A-frame before lubricating. Use a water-soluble cleaner such as Voom RV (part number 9911) – it does an exceptional job of breaking down road film, dirt and grease.

CAUTION

Do not use petroleum-based products to clean or lubricate the A-frame. Petroleum will attract dirt and dust, which will make the arms difficult to slide.

Clean all moving components, paying special attention to the inner arms and the locking mechanisms. Spray a liberal amount of cleaner on the inner arms and into the Autowlok buttons (Figure 3). Then, spray cleaner into the hole under each Autowlok button. Push and release each button, to work the cleaner into the locking mechanism.

Push each Autowlok button down, and retract and extend each A-frame arm several times. As the arm closes, the cleaner will lift dirt and debris from the interior of the outer

arm and the locking mechanism. Wipe the dirt and debris off and repeat, if necessary, until each arm is clean.

After cleaning the A-frame, wipe any remaining cleaner away.

Now that you have a clean, dry A-frame, use a dry silicone aerosol, such as LubeMaster (part number 747), to lubricate the A-frame – spray a liberal amount of silicone into all moving components, including the Autowlok buttons.

Flex the A-frame components, and push and release the Autowlok buttons, to work the lubricant in.

CAUTION

Always clean the locking mechanisms, as described above, before lubricating them. Silicone coats and covers in a thin layer. If it is not removed, it will reduce the clearance for the locking mechanisms, preventing proper operation.

Lubricate the coupler ball socket and ball clamp. The manufacturer's instructions are on the next page

Coupler information

Following are the coupler manufacturer's operation, latching and maintenance instructions, for your reference.

Assembling, operating and maintenance instruction of coupling heads ZSK and BC type

1. Introduction

Coupling heads are made in accordance with the Directive 94/20/EWG and the Regulations ECE-R55. Coupling heads are of great importance for road safety, therefore numerous tests have been carried out to confirm their reliability. Nevertheless, to ensure their reliability it is essential that coupling heads are properly assembled, operated and maintained. Therefore, please read this instruction very carefully and follow all the directions.

2. Range of application

Coupling heads can be used only with those trailers where the required parameters marked on the trailer casing have not been exceeded. All coupling heads are to be coupled with A class tow-hook balls (50 mm in diameter) that are made in accordance with the Directive 94/20/EWG and the Regulations ECE-R55.

Ranges of rotation – see Figure A

3. Assembling instruction

A coupling head should be fastened so that the coupling point of the trailer (with horizontal positioning of the bodywork, the maximum permissible "Pmax" axle load and properly placed load) does not exceed the permissible S value (vertical thrust) engraved on the body of the coupling head, and is 430 ±35 mm above the surface of the tyre adhesion to the ground – see Figure B. All deviations must be taken into consideration when approving the trailer construction. Coupling heads (depending on a design) may be fastened onto pipe shafts (round or square), V-shaped shafts and inertia brake couplings.

3.1. Assembling to a pipe shaft (round or square)

The casing of the coupling head should be placed on the shaft, properly positioned to the holes and screwed down with 2 bolts, 2 self-retaining nuts, 4 washers and 2 distancing jointing sleeves – see Figure C. When there are three vertical fastening holes, only two are to be used i.e. the front fastening hole and one of the rear ones.

3.2. Assembling to a V-shaped shaft

The recommended way of fastening the coupling heads of ZSK-750K and BC-800L type to a V-shaped shaft with steel sections that are up to 24 mm wide and up to 60 mm high with the use of a connector, horizontally placed 4 fastening screws M12x35 (ISO 4017), 4 self-retaining nuts, M12 (ISO 7040), and 8 washers 12.5 mm inside diameter (ISO 7090), is shown in detail in – see Figure D.

The other method of fastening the coupling heads of ZSK-750K and BC-800L type to a V-shaped shaft with steel sections that are up to 30 mm wide and over 60 mm high with the use of a connector, 2 vertically placed fastening screws M12 x 35 (ISO 4017), 2 self-retaining nuts M12 (ISO 7040) and 4 washers 12.5 mm inside diameter (ISO 7090) – see Figure E.



It is obligatory to check if all the bolts are screwed down properly after 1,000 kilometers.

4. User's manual

In order to couple and uncouple the trailer safely one should

- Make sure that there is a vacant space round the ball of the hook to exclude possible collisions with the spare wheel, frame and other bodywork elements.
- The trailer should be loaded properly, without exceeding the permissible total weight "Pmax," so that the thrust on the coupling ball does not exceed the "S" value (marked on the body of the coupling head) – see Figure B.
- To make sure that the coupling head is properly fixed it is important to check the position of the indicator and the clearance between the coupling head and the ball of the hook – see Figure F.
- If the coupling between the ball and the coupling head slackens e.g. clatters start occurring during driving, it means that either the ball or the coupling head is used up and should be replaced at once. The diameter of the ball should be at least 49.13 mm. If the value is smaller it indicates that the coupling ball is used up.
- If a coupling head should get damaged or deformed in an accident or because of overload, it should instantly be replaced.
- Being of great importance for road safety, coupling heads should not be altered in any way.

5. Operating instructions of BC and ZSK type coupling heads

- In order to open the coupling head, push the safety bolt 'R' with the index finger upward and turn the coupling handle 'D' forward – see Figure G.
- The coupling head is opened when the indicator is in the OPEN position – see Figure F.
- In order to couple a coupling head, place the opened coupling head on the ball and push the coupling handle 'D' downward – see Figure H, until the bolt 'R' clicks outside.
- The coupling head is coupled properly if the safety bolt 'R' clicks outside and the indicator is in position  – see Figure F.
- If the indicator is in position  – see Figure F, it means that either the coupling head is fixed incorrectly or that the parts of the coupling head or the ball are worn and should be replaced immediately.

6. Maintenance

Proper maintenance will provide easy exploitation and proper functioning of a coupling head. To ensure that all joints and bearings should be lubricated – see Figure G, and the holding clamp should be cleaned and lubricated regularly.

Table of tightening moments for screws

Screw Size	Resistance Class	Tightening Moments
M10	8.8	46 Nm
M12	8.8 / 10.9* / 12.9**	79 Nm / 115 Nm / 137 Nm
M14	10.9*	180 Nm

* Use for fitting the ball couplings of permissible maximum mass of a trailer above 1500kg to 2999kg.

** Use for fitting the ball couplings of permissible maximum mass of a trailer above 3000kg.

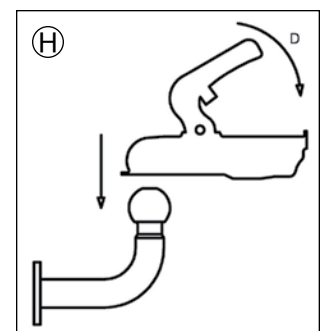
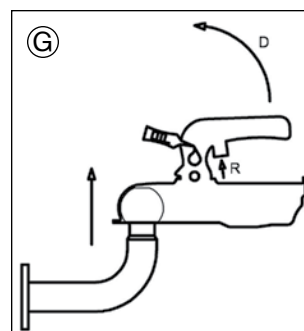
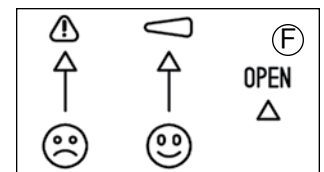
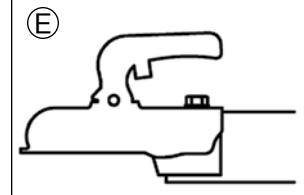
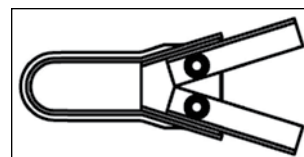
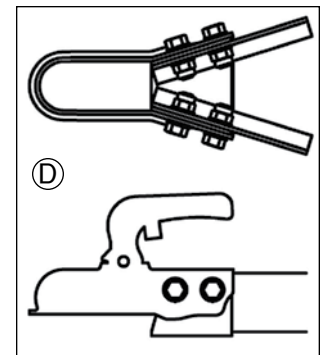
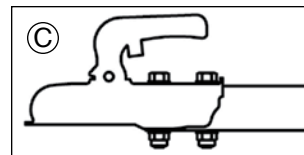
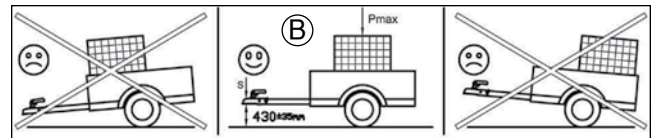
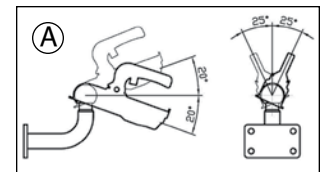

Limited warranty

READ THESE WARRANTY TERMS CAREFULLY BEFORE USING THE PRODUCT PURCHASED UNDER THIS WARRANTY. YOUR USE OF THE PRODUCT OR ANY OF ITS COMPONENTS INDICATES THAT YOU AGREE TO BE BOUND BY THESE TERMS AND CONDITIONS. IF YOU DO NOT AGREE TO ALL OF THESE TERMS AND CONDITIONS, RETURN THE PRODUCT TO THE PLACE OF PURCHASE FOR A FULL REFUND.

For products sold to businesses and commercial enterprises the terms and conditions under Section A apply. If the Buyer is a **private individual** who does not conclude the contract for the purpose of a trade, business, profession or commercial activity, the terms and conditions under Section B apply.

A. WARRANTY TERMS FOR BUSINESSES AND COMMERCIAL ENTERPRISES

1a. WARRANTY OF CONFORMITY AT TIME OF SALE

Roadmaster, Inc. ("Roadmaster") warrants that at the time of sale of this product it will be free from defects in material and manufacture and will conform to Roadmaster's specifications for the product.

1b. CONDITIONAL ONE-YEAR WARRANTY

In addition to the preceding time-of-sale warranty, if the product registration card is completely and accurately filled out and mailed to Roadmaster within thirty (30) days of purchase, Roadmaster will provide an additional warranty that for a period of one year after sale the product will remain in good working order, PROVIDED THAT the product is installed and maintained in accordance with Roadmaster's instructions. This warranty extends only to the first retail purchaser-consumer of the product and is not transferable.

This warranty does not cover:

- a. regular maintenance, normal wear and tear of the product or costs related to the removal, installation, or troubleshooting of the customer's installation;
- b. consumables (components that require periodic replacement during a product's lifetime);
- c. damage to the product, if it has been misused, neglected, improperly installed, physically damaged or altered, either internally or externally, or damaged from improper use, maintenance, or storage, or from abuse, or from use in an unsuitable environment;
- d. damage to the product, if it has been subjected to fire, water, generalized corrosion, biological infestations, negligence, accident, vandalism, disasters, war, severe weather, flooding, or Acts of God;
- e. damage to the product; if repairs have been done to it other than by Roadmaster or its authorized service centers;
- f. damage to the product, if it is used as a component part of a product expressly warranted by another manufacturer; or
- g. damage to the product, if its original identification (trade-mark, serial number) markings have been defaced, altered, or removed.

2. DISCLAIMER OF OTHER WARRANTIES

The preceding warranties are the exclusive and sole express warranties given by Roadmaster. They supersede any prior, contrary or additional representations, whether oral or written. No agent, representative, dealer or employee has the authority to alter or increase the obligations or limitations of this warranty. Any implied or statutory warranties, including any warranty of general or particularized fitness or quality or performance are disclaimed and excepted, unless local law prevents or limits such disclaimer, in which case any such implied or statutory warranties are disclaimed and/or limited to the extent permitted under local law.

3. EXCLUSIVE REMEDY FOR ANY NONCONFORMITIES

If during the applicable Warranty Period, the product does not conform to the preceding Warranties, notify Roadmaster as provided below, and within a reasonable time Roadmaster will provide, at its option, one of the following: (1) replacement components for any nonconforming or defective product or components or (2) the percentage of the purchase price for the non-conforming product equal to the percentage of the Warranty Period remaining when Roadmaster is notified of the nonconformity. Roadmaster will, at its option, (a) use new and/or reconditioned parts in performing warranty repairs and making replacement products, (b) use parts or products of original or improved design in the repair or replacement. If Roadmaster repairs or replaces a product, its warranty continues for the remaining portion of the original Warranty Period or 60 days from the date of the return shipment to the customer, whichever is greater. All replaced products and all parts removed from repaired products become the property of Roadmaster. Roadmaster will not provide, and will not be liable for, labor, costs of removal or reinstallation of components, disposal, shipping, freight, taxes, or other incidental charges. THESE REMEDIES ARE THE EXCLUSIVE AND SOLE REMEDIES FOR ANY BREACH OF WARRANTY.

For any breach of warranty, the Owner must contact Roadmaster within thirty (30) days after discovering the nonconformity. Do not return any product without first calling Roadmaster and getting a return authorization number. Returned products must include the return authorization number and a copy of the original invoice, bill or other proof of the date of purchase. The date of purchase must coincide

with the original warranty registration card on file. Roadmaster will authorize (a) shipment of the product to Roadmaster or (b) repair or replacement at the nearest warranty service center—in both cases with shipping at your expense. Do not purchase replacement parts or pay for repair labor—your will not be reimbursed. Compliance with the requirements of this paragraph is a condition to coverage under the Warranty: if these requirements are not complied with, Roadmaster will have no obligation to provide any remedy for any breach of warranty.

4. **DISCLAIMER OF INCIDENTAL AND CONSEQUENTIAL DAMAGES**
IN NO EVENT SHALL ROADMASTER BE LIABLE FOR ANY INCIDENTAL, SPECIAL, INDIRECT OR CONSEQUENTIAL DAMAGES, WHETHER RESULTING FROM NONDELIVERY OR FROM THE USE, MISUSE OR INABILITY TO USE THE PRODUCT OR FROM DEFECTS IN THE PRODUCT.

5. ADDRESS FOR NOTICES TO ROADMASTER

Roadmaster, Inc., 6110 NE 127th Ave., Vancouver, WA 98682

B. WARRANTY TERMS FOR INDIVIDUALS (CONSUMERS)

The General Terms and Conditions, mentioned below, apply to the contractual relationships with private individuals, who do not use the Product for the purpose of a trade, business, profession or commercial activity.

1a. STATUTORY WARRANTY

Roadmaster grants to its buyers the warranty prescribed by the domestic statutory law regarding consumer warranties in effect where the consumer buys the product, subject to the following terms, provided that such terms are permitted by the domestic law.

1b. ADDITIONAL WARRANTY

Roadmaster grants to its buyers the following warranty in addition to the statutory warranty prescribed by the domestic statutory law regarding consumer warranties in effect where the consumer buys the product. Where the domestic law provides greater rights, its provisions shall apply:

Roadmaster warrants that at the time of sale of this product it will be free from defects in material and manufacture and will conform to Roadmaster's specifications for the product. In addition, Roadmaster will extend to any consumer buyer the terms and benefits of the Conditional Warranty for Businesses and Commercial Entities and the Extended Warranty, described above under Section A.1.b, above, provided that the consumer buyer fills out and returns the product registration card within the time periods described in that section.

2. REMEDY FOR ANY NONCONFORMITIES

If during the applicable Warranty Period, the product does not conform to the preceding Warranties, notify Roadmaster as provided in Section 3 of the Warranty Terms for Businesses and Commercial Enterprises, above, and Roadmaster will provide the remedy specified in that Section, in accordance with the terms of that Section—provided that Buyer will also be entitled to any additional or different rights and/or remedies required under the Buyer's national law. THE REMEDIES PROVIDED IN SECTION 3 ARE THE EXCLUSIVE AND SOLE REMEDIES FOR ANY BREACH OF WARRANTY—provided that Buyer will also be entitled to any additional or different remedies required under the Buyer's national law.

3. LIMITATIONS AND EXCLUSIONS OF LIABILITY

Liability shall be excluded for consequential damages, e.g. loss of profits, inability to achieve cost savings, and other indirect damages. Roadmaster shall not be liable in case of infringements or immaterial contractual obligations resulting from Roadmaster's simple negligence. Roadmaster shall be liable to the full statutory extent in case of intentional misconduct or gross negligence by its organs (the board, a member of the board, or other duly appointed representative) or executive staff. Moreover, Roadmaster will be liable even in case of simple negligence as regards infringements of essential contractual obligations (essential rights or duties resulting from the nature of the contract) on the fulfillment of which the Buyer may rightfully rely. In this case and in case of intent or gross negligence by any other person employed by Roadmaster in performance of Roadmaster's obligations (excluding organs and executive staff), Roadmaster shall be liable only for typically foreseeable damages having regard to the evidently prevailing circumstance.

The above limitations of liability shall apply to all claims for damages without regard to the legal cause. The limitations shall not apply to claims based on personal injury and shall not reduce liability according to product liability laws and liability for breach of an express warranty given in regard to characteristics or durability of the goods. The above limitations of liability shall apply also for the benefit of Roadmaster's employees or any third person instructed by Roadmaster. Consumers have statutory rights under applicable national laws relating to the sale of consumer products. This warranty does not affect statutory rights that you may have or your rights against the entity from which you purchased the product, and it does not curtail or limit those rights that cannot be excluded or limited. Roadmaster grants all warranties prescribed by your national statutory law, subject to the following provision:

If the Buyer is entitled to claim damages pursuant to the national law, Roadmaster's liability is limited by this section.

Optional equipment and accessories

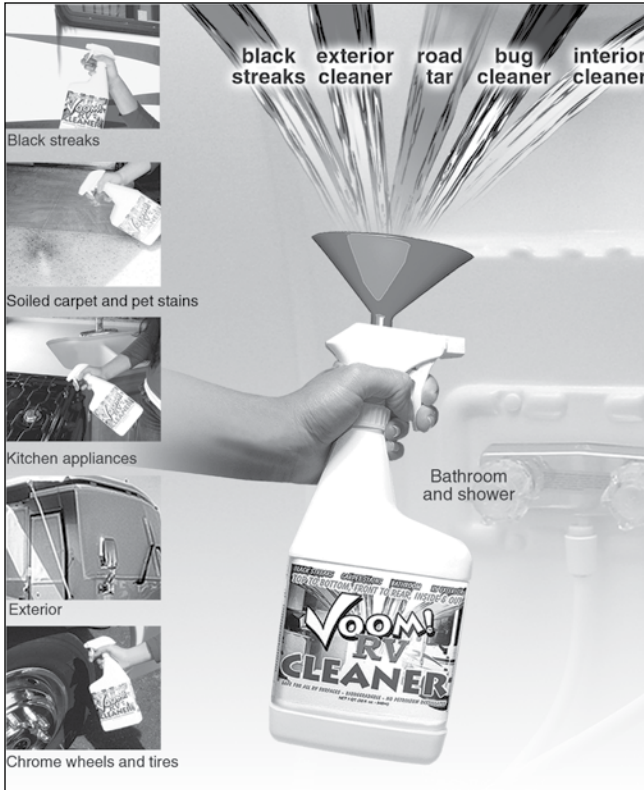

Voom™ RV

The newest cleaning technology in Voom RV allows you to use only one cleaner for all of your RV's cleaning and maintenance. From top to bottom, front to rear, inside and out, Voom RV is the only cleaner you will ever need.

Voom RV is an all-purpose cleaner that's safe for all surfaces not harmed by water. And it's safe for the planet – Voom RV is biodegradable and contains no petroleum distillates. Great for around the home, too!

Exterior uses: A-frames; aluminum; awnings; black streaks; chrome; bug stains; painted surfaces; rubber; rubber roofs; screens; tar; wheels and more! Interior uses: appliances; carpets; counter tops; fiberglass; grease; hard water stains; mold and mildew; pet stains; spot cleaning; tubs; toilets; upholstery.

9911 Voom RV 32 oz. spray

LubeMaster™ silicone spray

LubeMaster is the ideal lubricant for A-frames, awning arms, window tracks, folding steps or for hundreds of other applications around the home and motorhome.

It's a dry silicone, which does not attract dirt or road grime that can cause binding.

Meets Volatile Organic Compound (VOC) standards.

747 LubeMaster

